

Standard Version On/off Control

Model: HC009S

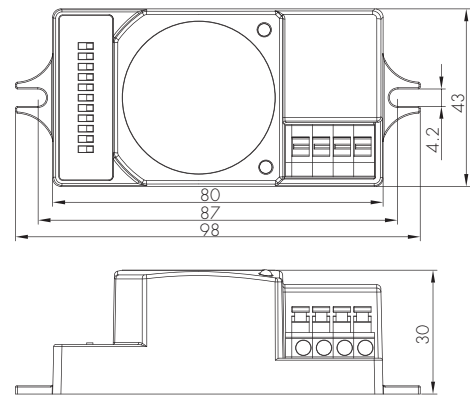
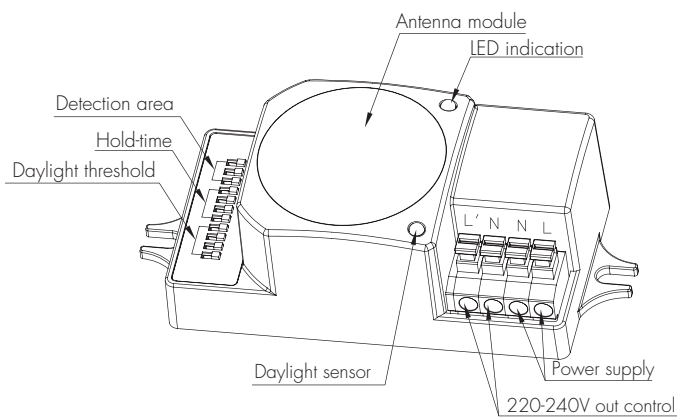

Functions and Options

1 On-off Control

This sensor is a motion switch, which turns on the light on detection of moving objects, and turns off after a pre-selected hold-time when there is no motion detected. A daylight sensor is also built-in to prevent the light switching on when there is sufficient natural light.

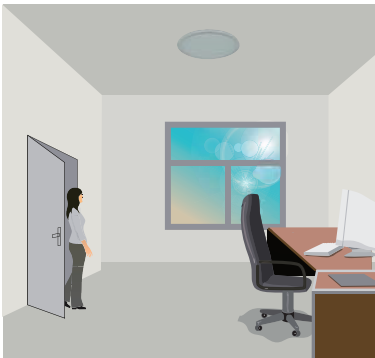

With sufficient natural light, the light does not switch on when presence detected.

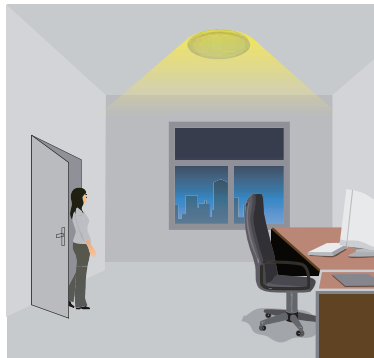

With insufficient natural light, the sensor switches on the light automatically when person enters the room.

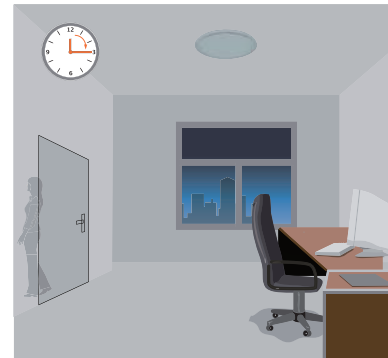

The sensor switches off the light automatically after the hold-time when there is no motion detected.

2 100H burn-in mode for fluorescent lamp

Switch the power supply to the sensor three times within 3 seconds, light will be 100% on for 100 hours, and then automatically goes to sensor mode after 100 hours. This is crucial to secure the lifetime of fluorescent lamp, when new fixture is installed, or old lamp is replaced.

Note: this 100H burn-in feature can be cancelled by turning off/on the fixture 1 cycle within 1 second.

3 Condominium control function

In many cases, several sensors are connected together to control the same fixture, or to trigger on each other, the sudden on/off of the lamp tube or the ballast/driver causes huge magnetic pulse, which may mis-trigger the sensor. This sensor has a very advanced software to ignore that interference.

By connecting L' terminal with L' on another sensor, if any of the master fixture (containing sensor) is triggered, all luminaries (including slaves and other master unit in the group) will also light up.

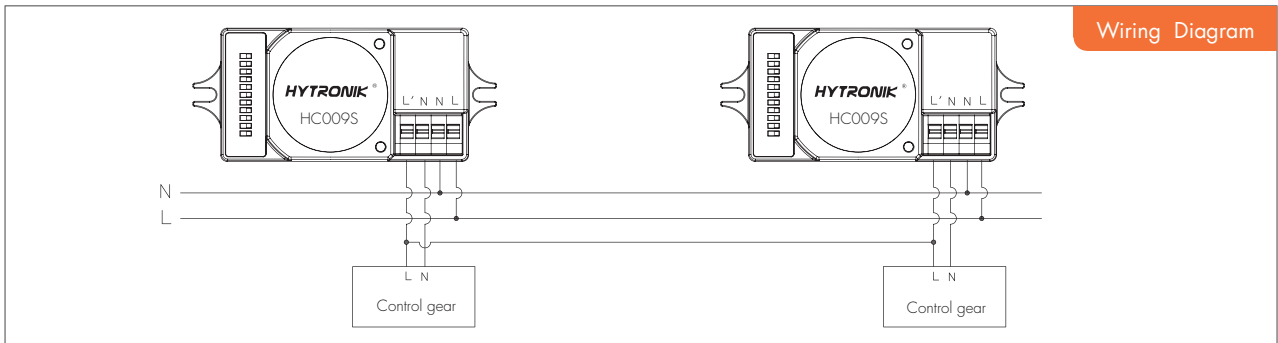

4 Ambient daylight threshold

Switch the power supply to the sensor two times within 2 seconds, the sensor can set the ambient lux level as the new threshold. Both the settings on DIP switch and the ambient lux threshold learned can overwrite each other. This feature enables the daylight sensor to be commissioned to the environment in which it is installed. The latest action controls. (More details of the operation procedure please refer to user manual).

5 Zero-cross relay operation

Designed in the software, sensor switches on/off the load right at the zero-cross point, to ensure the in-rush current is minimised, enabling the maximum lifetime of the relay.

6 Loop-in and loop-out terminal

Double L N terminal makes it easy for wire loop-in and loop-out, and saves the cost of terminal block and assembly time.

7 Tri-level dimming control

With Tridonic switchDIM ballast/driver (Excel ballast/driver, corridor function), this sensor can also achieve tri-level dimming control.

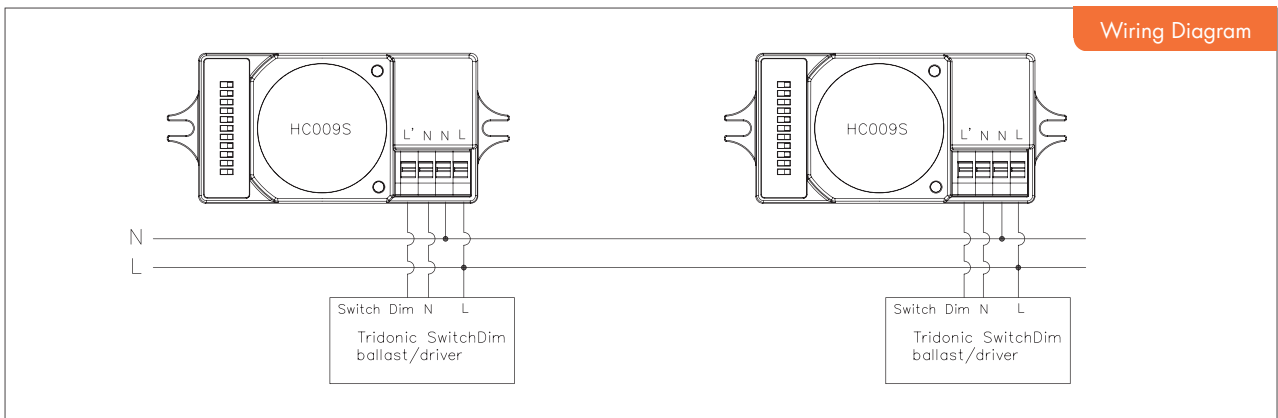

Detection Pattern

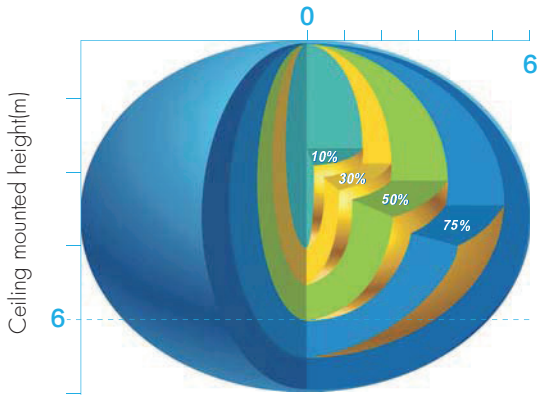

Ceiling mounted detection pattern (m)

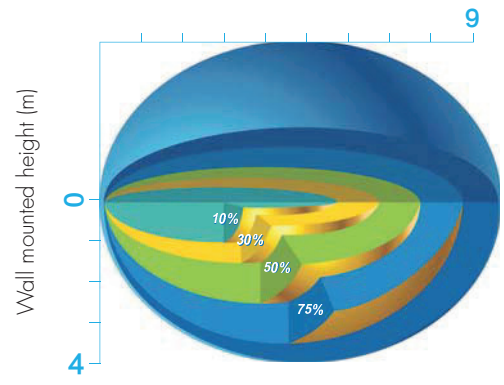

Wall mounted detection pattern (m)

Settings

1 Detection area

Detection area can be reduced by selecting the combination on the DIP switches to fit precisely for each specific application.

	1	2	3	
I	●	●	●	100%
II	○	●	●	75%
III	●	○	●	50%
IV	●	●	○	25%
V	○	○	○	10%

I – 100%
II – 75%
III – 50%
IV – 25%
V – 10%

2 Hold-time

Hold-time means the time period you would like to keep the lamp on 100% after the person has left the detection area.

	1	2	3	4	
I	●	●	●	●	5s
II	○	●	●	●	30s
III	●	○	●	●	1min
IV	●	●	○	●	5min
V	●	●	●	○	15min
VI	○	○	○	○	30min

I – 5s
II – 30s
III – 1min
IV – 5min
V – 15min
VI – 30min

3 Daylight sensor

The daylight threshold can be set on DIP switches, to fit for particular application.

“Daylight” : The lamp works always, even during daylight.

“Twilight” : The lamp works only in twilight .

“Darkness” : The lamp works only in darkness.

	1	2	3	4	
I	●	●	●	●	2Lux
II	○	●	●	●	5Lux
III	●	○	●	●	10Lux
IV	●	●	○	●	30Lux
V	●	●	●	○	50Lux
VI	○	○	○	○	Disable

I – 2Lux
II – 5Lux
III – 10Lux
IV – 30Lux
V – 50Lux
VI – Disabled

Note: end-user can also scan the QR code on the housing for DIP switch settings.

Technical Data

Operating voltage	220-240VAC	
Switched power	Max.400W (capacitive)	Max. 1200W (resistive)
Stand-by power	<0.5W	
Warming-up time	20s	
Detection area	10/25/50/75/100%, can be customized	
Hold-time	5s/30s/1min/5min/15min/30min, can be customized	
Daylight threshold	2~50Lux, disable, can be customized	
Microwave frequency	5.8GHz+/-75MHz	
Microwave power	<0.2mW	
Detection range	Max. (øxH): 12m x 6m	
Detection angle	30°~150°	
Mounting height	Max. 6m	
Tc	85°C	
IP rating	IP20 IP65 (mounted in Hytronik special box)	
certificate	Semko, CB, EMC, CE, R&TTE, SAA	